

# Ingersoll Rand

75-350 kW Two Stage and 200-250 kW Single Stage  
Contact Cooled Rotary Screw Air Compressors



GRUPO JOSÉ PINTO  
COMÉRCIO GERAL, LDA

OFFICIAL DISTRIBUTOR OF



*Innovation*

*Reliability*

*Efficiency*



## Innovative Energy Efficient Design

**Energy efficiency is one of the most important considerations** in judging the successful operation of a compressed air system. Energy costs can often exceed the purchase price of equipment, even during the system's first year of operation.

On average, compressed air systems use 10% of the energy consumed by a production facility, so even small improvements help maximise plant energy efficiency. Ingersoll Rand's rotary screw air compressors are designed to help you reduce waste and lower your operating costs — here's how we do it.

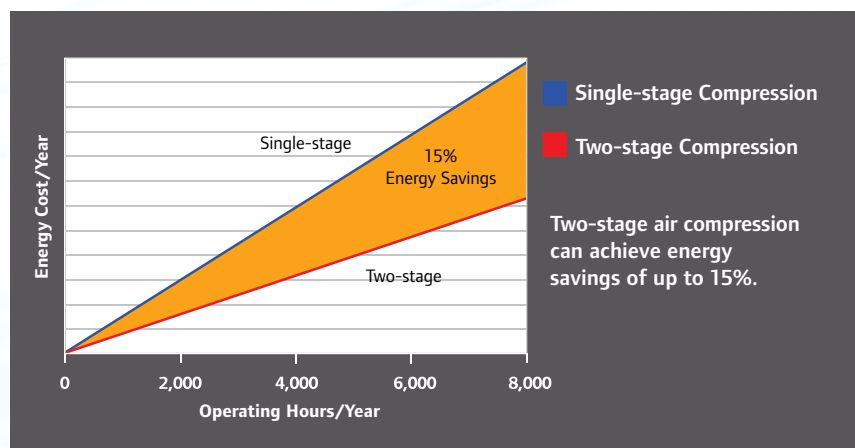

### Energy Efficient Airend Reduces Running Costs

If you're looking for the greatest efficiency possible, look no further than Ingersoll Rand's two-stage compressors. The heart of the compressor is our time-proven two-stage airend which compresses the air in two stages instead of the standard one stage, realising energy savings of up to 15%. Each of the stages of the airend have different objectives. The first stage is used for high displacement while the second stage achieves high efficiency of compression to the final package pressure.

*Progress is greener with Ingersoll Rand*

Ingersoll Rand offers industry-leading products and solutions that enable businesses around the world to reduce energy consumption and costs and decrease harmful environmental emissions. From air compressors that reduce energy consumption to electric-powered golf cars with near-zero emissions, Ingersoll Rand provides the knowledge, experience and solutions to help our clients achieve their sustainability goals.

### Energy Recovery System Option

The two-stage fixed speed compressor can be equipped with the Energy Recovery System (ERS) to minimise energy costs even further and benefit the environment. The Ingersoll Rand ERS coolant-to-water heat exchanger utilises the thermal energy captured in compressor coolant to heat the water up to 70°C. Energy costs can be significantly reduced by supplementing your current water heating system with recovered heat.

Examples of annual energy cost savings for a two-stage 160 kW compressor with ERS system when substituting the electric or gas heater are given below:

Water Heater Type	Energy Cost € / kWh	Compressor Rated Power kW	Cost Savings		
			1 Shift (48 hrs/ week)	2 Shifts (96 hrs/ week)	Full Time (168 hrs/ week)
Electric Heater	€ 0.05	160	€ 13,349	€ 26,697	€ 46,720
Gas Heater	€ 0.03	160	€ 8,009	€ 16,018	€ 28,032

NB: Potential savings calculated by multiplying available heat, compressor run-time and fuel cost, divided by water heater efficiency.

### Coolant Curtain...for more Energy Savings

One of the keys to the efficiency of the two-stage design is the coolant curtain. Significant cooling of the air is achieved by injecting atomised oil into the compressed air stream leaving the first stage. Lowering the air temperature prior to entering the second stage significantly decreases the energy required for compression. The coolant curtain also eliminates the need for an intercooler.

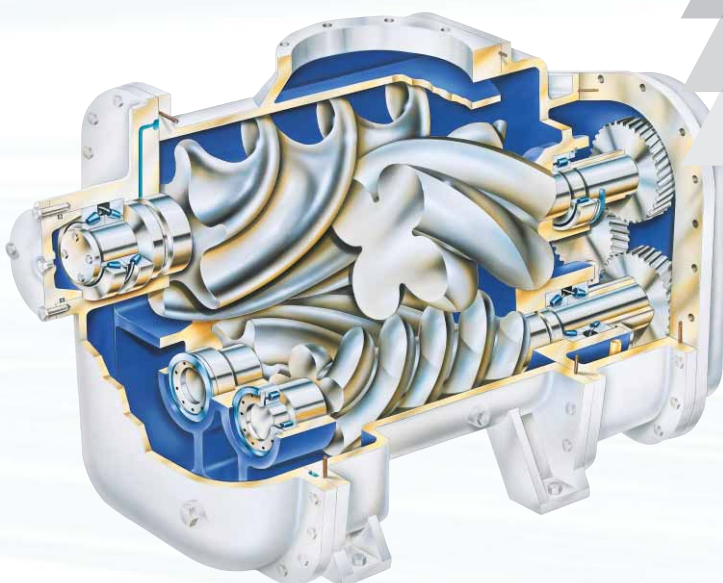
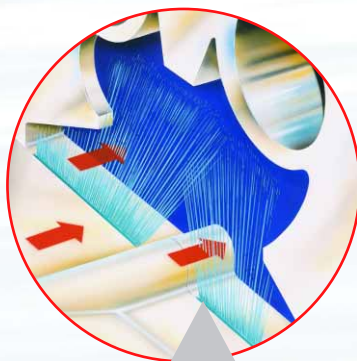

### Energy flow in typical air-cooled, contact-cooled compressor

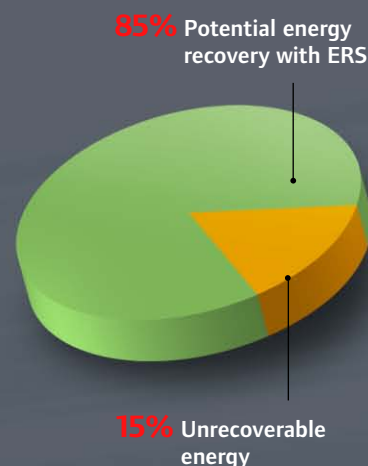

Hot water heated by ERS can be used in a variety of applications, for example:

- ▶ Pre-heated boiler feed water
- ▶ Process water
- ▶ Tap water
- ▶ Heating applications

In fact, all other applications that require warm water!

# Rotary Screw Air Compressors... Reliability at Your Fingertips

Competing in today's business environment requires manufacturers to keep their operating systems up and running. When systems go down, production stops. **Reliable, flexible and easy to use equipment is essential for efficient operation.**

## Ultimate durability

Focusing on reliability, Ingersoll Rand rotary screw air compressors are designed with a unique, maintenance-free drive system — a simple gear drives the airend. Since the motor and airend are permanently aligned, no adjustments are needed during the course of normal operation. Additionally, since no inspection covers are required, the gear drive provides a user-safe means of turning the airend.

At the core of Ingersoll Rand's rotary compressors, is a rugged airend that uses duplex tapered roller bearings. These roller bearings provide linear contact for thrust loads, dramatically improving airend life.

Used in thousands of compressors throughout the world, Ingersoll Rand's airend has earned a reputation for trouble-free operation and minimal maintenance.

## Superior 2-Stage airend

At the core of Ingersoll Rand's rotary two-stage compressors is an airend designed to operate at a very low speed. Additionally, the pressure ratio is split into two stage, so the load of the bearings is significantly reduced and the life of the airend is extended.

Both the first and second stages of the airend share the same cast iron casing, removing any unnecessary connections between the stages. This solution eliminates leaks and reduces pressure drop within the compression module.

Bearing Coolant Dam

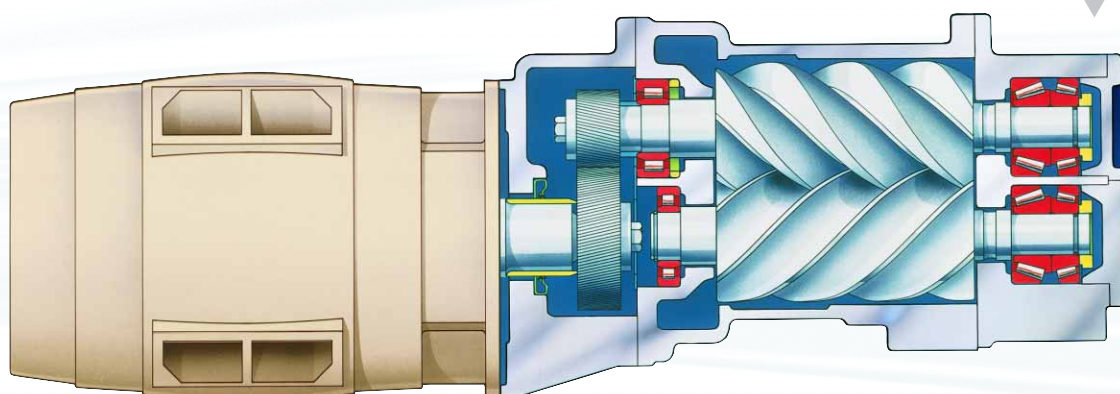
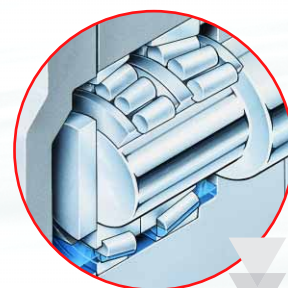

### **Precise One-touch Control with Intellisys®**

Whether the application requires eight hours of continuous-duty compressed air or an intermittent supply over a 24-hour period, the Intellisys® microprocessor is in complete control. The Intellisys controller provides quick, comprehensive access to your compressed air system at the touch of a button — nothing could be more intuitive and user-friendly. The compressor's operating parameters can be quickly and easily adjusted to meet the plant air system's requirements and minimise operating costs.

### **Automatic Service Prompts for Ensured Maintenance**

Intellisys indicates when it is time to perform maintenance. This function encourages routine service in a timely fashion, thereby increasing uptime.

### **Timesaving Diagnostics**

Intellisys provides a fast diagnosis of system demand, displays a warning and stops the compressor if it exceeds operating parameters. It also provides a history of events leading up to the condition. This will keep troubleshooting expenses and downtime to a minimum. An easy-to-read, liquid crystal display (LCD) provides you with the critical details of the compressor's operation, allowing fast adjustments when necessary.

### **Ethernet remote connectivity**

It may be necessary to monitor the compressor parameters and alarms or control its operation remotely through the plant automation system. An Intellisys controller gives you this possibility with a common Ethernet connection.

### **Power Outage Restart Option (PORO)**

With the Power Outage Restart Option, following a disruption to your power supply, your compressor will be restored to its previous running condition once the power is reinstated to the compressor.



### **Power Conservation System (PCS)**

When low demand for compressed air is required, the compressor switches to unloaded running and then may even stop. PCS decreases the time of unloaded operation when the compressor is going to stop. Therefore, reduce non-productive operations and energy costs when using PCS.

# Superior Features that Reduce Operating Costs

Ingersoll Rand rotary screw compressors add unequalled reliability, efficiency and productivity to virtually any compressed air system.

## Convenient Top Exhaust

The cooling air flow discharges from the top of the package facilitating easy ducting for removal and/or recovery of exhaust heat.

## Air or water cooled Packages

To fit the needs of the compressed air system Ingersoll Rand offers the choice of an air-cooled or water-cooled design.

## Water Separation Components

The water separator and drain valve are included in this package, making installation straightforward and less time consuming.

## Easy Serviceability

Our total package is remarkably orderly, making servicing easy. All components are readily accessible behind easily removable panels.

## Voltage Options

Depending on the site electrical installation, compressors can be supplied with a range of electric motors from 400V up to 6,600V, avoiding replacement of electric cables and switchboards.

## Food Grade Coolant Option

The air compressor is available factory filled, with Ingersoll Rand X-tend Food Grade Coolant and Filters. This will aid compliance with food industry standards.

## ISO 14000

Ingersoll Rand air compressors are designed to support the environmental policies of ISO 14000.



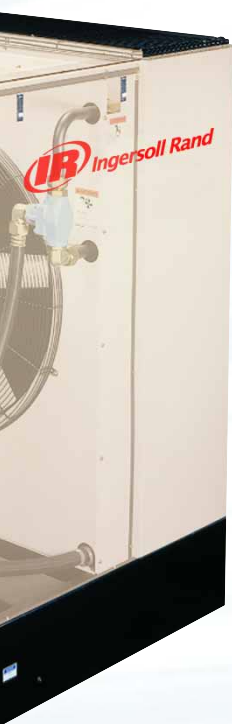

### **Up to 46°C (115°F) Operating Ambient**

Our rotary screw compressors operate in high ambient conditions, making them suitable for locations around the world. Even if the compressor is not operated in sweltering climates, the high temperature rating ensures fewer nuisance shutdowns caused by fouled coolers.

### **End-to-end Cooling**

The aftercooler is located at the inlet end of the package. This allows cool compressed air as low as 8°C (46°F) above the ambient temperature to pass downstream to the air system.

### **Durable Motor**

The motor is designed to be as rugged as possible, however the efficiency is not compromised in any way. This motor will ensure the most economical running of your compressed air system. The life-time of the motor is significantly increased due to its class F insulation with class B temperature rise.

### **Quiet Enclosure**

A low sound enclosure is standard and keeps sound levels to a minimum.

### **Factory Tested**

Every rotary screw compressor undergoes state-of-the-art testing to ensure that you get the best possible performance under varying conditions.

## **8,000 Hour/ 2-year Lubricant**

Ultra Coolant™ reduces maintenance costs by lasting longer between changes. Also, because of its superior separation properties, less coolant is passed downstream to the air system, further minimising coolant replacement costs.

Finally, Ultra Coolant's biodegradable properties eliminate the need for an oil-water separator, thereby reducing the problems associated with condensate disposal (Subject to local approval).



# Engineering the Right System for Your Application

System Design 1  
Small system or single compressor

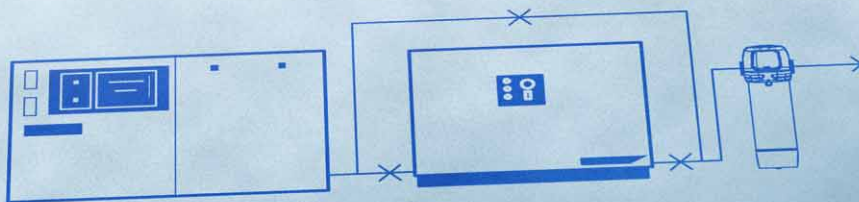

Compressor with integrated air treatment and bypass

## When Do I Use Integrated Dryers with My System?

Compressors with integrated dryers make sense for smaller systems of typically 37 kW and below, and point-of-use applications where a single compressor often carries the load of the entire system. In those cases, the compressor's discharge pressure is the system pressure and, as such, control issues do not arise.

System Design 2  
Larger, centralized system



Multiple compressors with compressed air trains

## Avoid Problems of Compressed Air Trains

As systems grow, multiple compressors with connected or integrated air treatment can have negative effects on optimisation and pressure stability. Multiple dryers and filters — in what are known as “compressed air trains” — cause significant system losses and make control optimisation impossible.



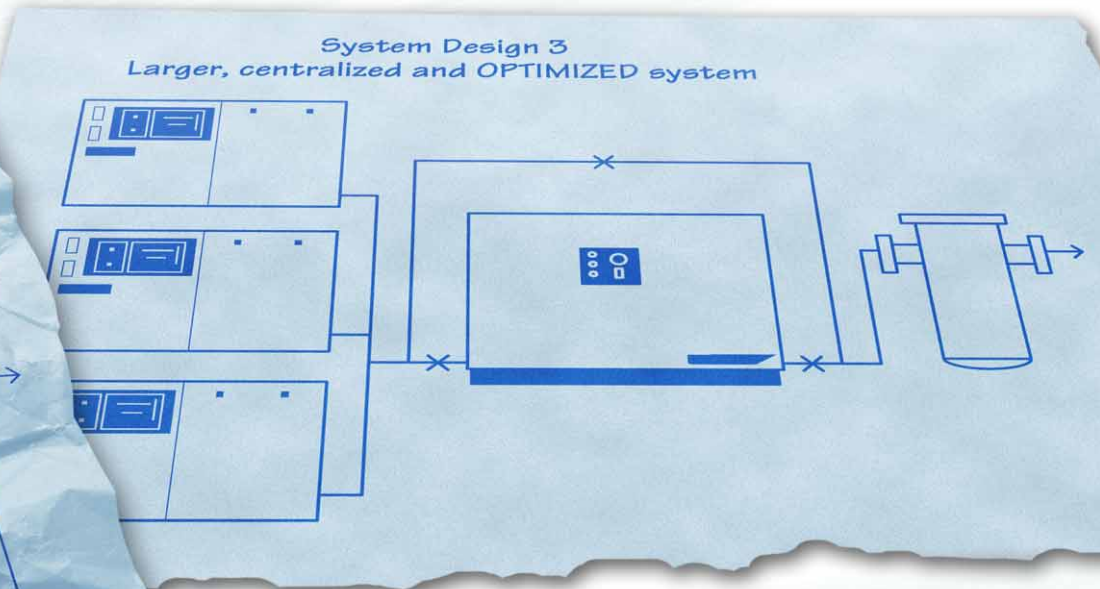
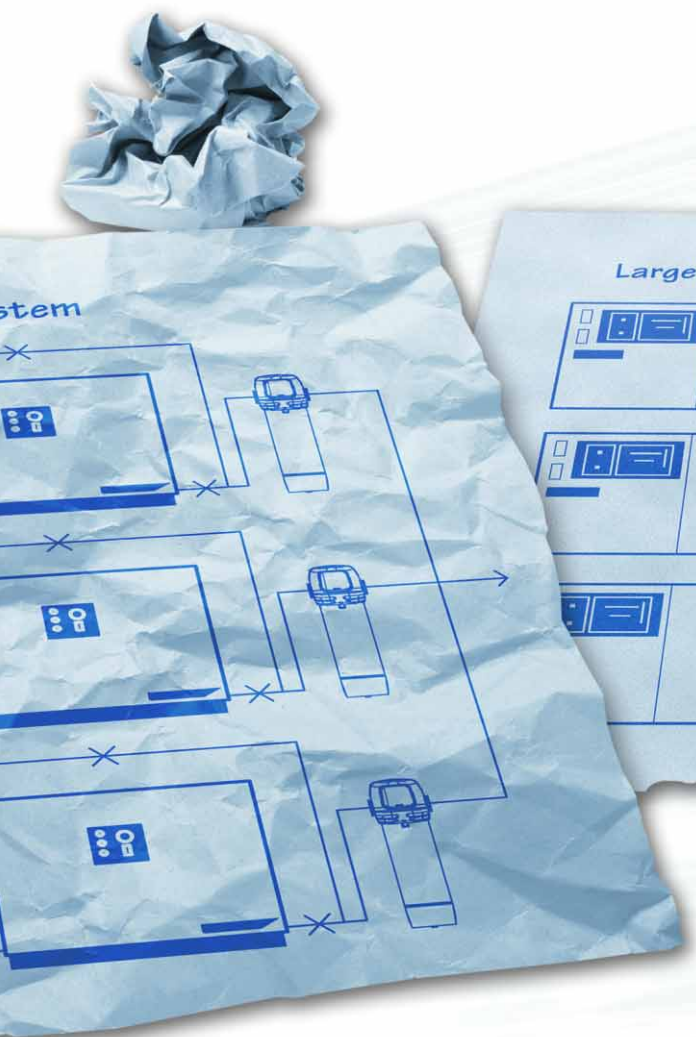

Multiple compressors with optimised air treatment

## Proper Design of Larger Centralised Systems

Eliminating integral compressed air trains allows for system design optimisation. There are a number of benefits associated with a centralised air system with fewer dryers, such as:

- Dryers can be sized to optimise the system
- Lower energy losses through lower pressure drop with lower loads
- Better dew point control
- Compressor controls manage a single air treatment system
- Energy savings and minimised CO<sub>2</sub> emissions through reduced compressor pressure setting
- Stabilised pressure

They can also cause:

- Higher energy losses due to pressure drops
- Dew point variability
- Increased maintenance due to frequent compressor cycling from variable pressure drops across each train
- Artificially higher supply pressure required to account for variable pressure drop and control issues
- Reduced effective pressure control band due to need to respond to the highest pressure drop in the train

# Intelligence for your air system

Ultimate system optimisation can be achieved using the Ingersoll Rand X-Series System Automation.



X12I System Automation



X8I System



X4I System Automation



VX System Visualisation

## Optimised System Operation

X-Series System Automation eliminates waste by managing up to twelve positive displacement compressors simultaneously. This includes compressors of different capacities, different types (fixed speed, variable speed and variable capacity) and in any combination or configuration.

Through advanced control functionality and universal connectivity, the X-Series System Automation products will work with your existing compressors, from Ingersoll Rand or any manufacturer, to improve operating efficiency, reduce energy costs and eliminate waste!

Here's how the X-Series products deliver a unique combination of efficiency, reliability and tremendous cost-savings:

- Operate compressors only as needed, bringing standby compressors on-line incrementally during periods of peak demand.

- Manage the compressed air system at your minimum required pressure without compromising air supply reliability.
- Dynamically match the most energy-efficient compressor or combination of compressors with compressed air demand.
- Operate one or more variable speed compressors to minimise wasted energy due to unloaded compressor run-on time or short cycle operation.

## VX System Visualisation

The monitoring of your compressor system has never been so easy. Just add the VX module to an X-Series System Automation and you will gain complete system visibility. In addition to the compressor operating status, also visible are alarms and energy consumption trends either from local or remote computers. No special software is required just use a standard web browser.

# Reliable, Clean Dry Air

*Minimise problems and expenses with an efficient, reliable and environmentally friendly solution for cleaner, dryer air.*

## **Air Filtration**

Ingersoll Rand air filters feature our Element Replacement Indicator (ERI) – an illuminating approach to filter maintenance that yields real, measurable benefits for you, for your company and for our environment. With the Ingersoll Rand filters you will achieve a low overall air treatment pressure drop. Proactive servicing ensures that the cost of pressure drop is kept to the lowest possible level. Reactive servicing costs more money and can affect your productivity. (See our Air Filtration Brochure for more details).



## **Refrigerated Compressed Air Dryers**

The wide range of refrigerated dryers provides multiple choice for a variety of applications and site conditions. Equipped with corrosion-resistant heat exchangers, an enhanced control system and high efficiency moisture separation, ensures a long-term steady supply of dry air. This reduces additional costs associated with ruined product finishes, scrapped material or replacement of pneumatic tools destroyed by the wet air.

Ingersoll Rand refrigerated dryers offer multiple design features to ensure a constant dew point and will deliver a continuous dry air performance that satisfies ISO 7193 industry standards. The full function control with enhanced control parameters, diagnostics and alarms is more sophisticated and powerful than similarly sized competitive products. We test every unit to ensure leak-free operation and compliance with all operating specifications. The units are rated for 50°C ambient air conditions – suitable for most applications.



# Auditing, Service and Maintenance



## ▶ Papermaking

Even in the harshest manufacturing environments, rotary screw compressors add unequalled reliability, efficiency and productivity to your air system.

## ▶ Food Packaging

Ingersoll Rand drives productivity within this and other continuous or batch process industries by delivering advanced technology compressor solutions that provide low life-cycle costs.

## ▶ Textiles

Garment manufacturing requires a reliable source of clean, dry compressed air, which is why Ingersoll Rand has been a critical supplier to this industry for many years.

**No matter what the industry or location,** Ingersoll Rand is committed to serving you 24 hours a day, seven days a week. Our worldwide network of distributors, engineers and certified, factory-trained technicians are a phone call away — ready to support you with innovative and cost-effective service solutions that will keep you running at peak performance.



### **Ingersoll Rand UltraCare - Helping you maintain a healthy business**

A lot can (and will) happen over the life of a compressed air system. With ever increasing demands for machine availability, reducing production losses due to unplanned maintenance and downtime is essential.

That is why we offer UltraCare. A responsive, flexible, contract maintenance agreement, designed to provide Ingersoll Rand authorised scheduled maintenance ensuring increased system reliability and lowest energy. UltraCare eliminates unscheduled downtime and costly repairs.

Provided an Ingersoll Rand prefilter is installed you have 5 years peace of mind on the complete dryer.

#### **Contact us:**

**Tel:** +244 222 335 512

**Email:** [comercial@grupojosepinto.org](mailto:comercial@grupojosepinto.org)

[www.grupojosepinto.org](http://www.grupojosepinto.org)



**GRUPO JOSÉ PINTO**  
COMÉRCIO GERAL, LDA



### ▶ Metal Forming

Compressed air is too important to take chances, so engineers can maximise production uptime by specifying Ingersoll Rand rotary screw compressors, featuring our unique maintenance-free drive system.



### ▶ Assembly

Few industries have a greater need for energy efficiency — our single- and two-stage rotary screw compressors offer the best efficiency over the widest operating range.



### ▶ Printing

The printing industry relies heavily on compressed air, from pre-press through printing to shipping. High quality air and stable pressure are critical to minimise production interruption.

**Intellisurvey** - Fixing a troublesome system without first diagnosing the true problem is a hit or miss proposition based on guesswork. This can lead to production stoppages, extended downtime, and even product spoilage. Ingersoll Rand eliminates the guesswork by providing proven air system auditing services that not only ensure air system efficiency, but reduce operating costs to improve profitability.

#### **Air System Audit**

Using an innovative tool — known as Intellisurvey — we non-intrusively monitor a compressed air system to determine the root causes of symptoms. With Intellisurvey, our experts analyse the many components of an air system, as well as flow, pressure, supply utilisation, and power costs, to determine an optimised system that generates improvements in repeatability, efficiency, and plant productivity.

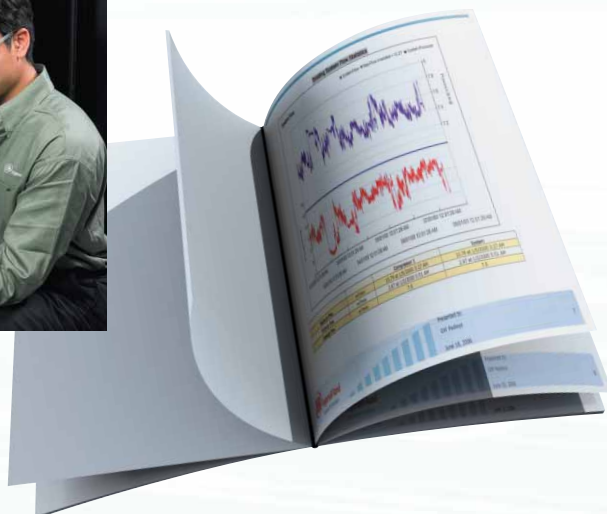

# Supreme Efficiency

## Specifications

50 Hz Single-stage 200-250 kW Performance							
Nominal kW	Free Air Delivery m <sup>3</sup> /min			Length mm	Width mm	Height mm	Weight kg
	ML 7.5 bar g	MM 8.5 bar g	MH 10.0 bar g				
200	34.3	32.9	30.2	4000	1930	2146	3930
250	43.9	42.5	38.8	4000	1930	2146	4688

50 Hz Two-stage 75-350 kW Performance								
Nominal kW	Free Air Delivery m <sup>3</sup> /min				Length mm	Width mm	Height mm	Weight kg
	ML 7.5 bar g	MM 8.5 bar g	MH 10.0 bar g	MXU 14.0 bar g				
75	15.7	14.2	13.1	-	3,270	1,620	1,900	2,690
90	18.0	17.5	15.4	12.5	3,270	1,620	1,900	2,710
110	22.1	20.4	18.9	15.4	3,270	1,620	1,900	2,860
132	26.2	24.2	23.1	18.4	3,270	1,620	1,900	3,120
160	31.1	29.6	27.2	22.2	3,270	1,620	1,900	3,120
200	41.5	38.8	36.2	28.6	4,000	1,930	2,146	5,460
250	49.2	47.4	44.2	36.4	4,000	1,930	2,416	5,540
300	60.2	56.0	52.1	44.3	4,000	1,930	2,416	6,870
350	69.2	64.1	59.5	50.2	4,000	1,930	2,416	6,900

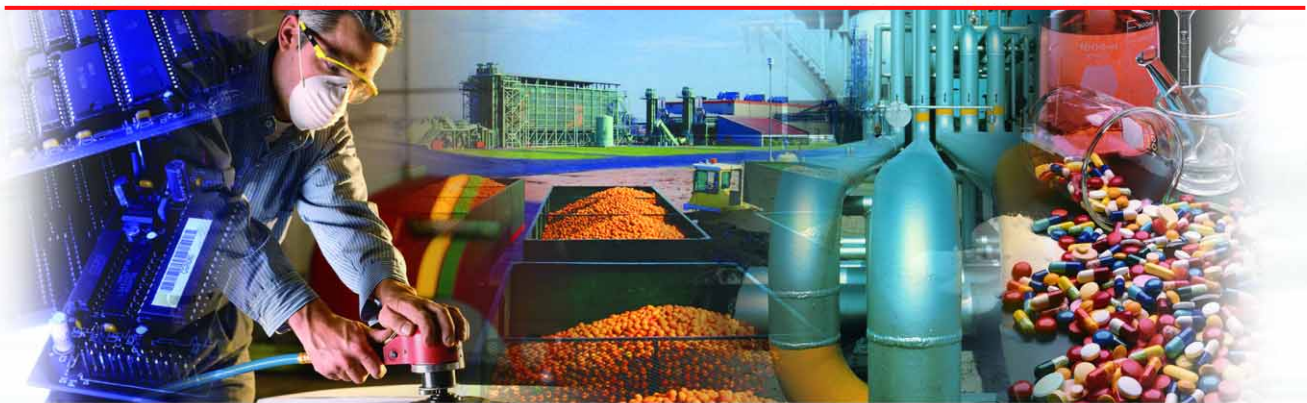

Ingersoll Rand Two Stage Compressors - provide ultimate efficiency over a wide range of capacity, realising savings during every hour of operation.

# A configuration for every need...

## Features and Options

Category	Description	Standard	Optional	
Main Motor	High efficiency IP 55 motor 75 - 160 kW	✓		
	High efficiency IP 55 motor 200 - 350 kW		✓	
	High ambient rated 46°C	✓		
	Class F insulation B temperature rise	✓		
Controller	Full compressor diagnostic with alarm history	✓		
	Automatic maintenance indication	✓		
	Load/ unload capacity regulation system	✓		
	Power Conservation System	✓		
	Remote monitoring and control by ethernet connection	✓		
	Automatic start/stop shut down timer	✓		
	Remote load and unload	✓		
	Modulation control	✓		
	Power Outage Restart Option (PORO)		✓	
	Multiple compressors system controllers		✓	
	Visualisation system		✓	
	Power	Star/delta starter	✓	
		Variable speed drive		✓
Soft starter			✓	
Phase monitor			✓	
Voltage - from 400V to 6600V			✓	
Anti-condensation heaters for main and fan motors			✓	
Thermal protection for main motor			✓	
Lubricant		8000 hr life UltraCoolant	✓	
	X-tend food grade coolant		✓	
	X-tend filtration system		✓	
Environmental	Low noise enclosure	✓		
	Designed to help meet ISO 14000 obligations	✓		
	Oil containing frame	✓		
	Energy Recovery System (ERS)		✓	
Auxiliary Systems	Cooling fan for air-cooled compressors	✓		
	Water separator and drain valve	✓		
	High dust filter		✓	
	Water-cooled		✓	
	Seawater-cooled		✓	
Convenience	Single point connectivity	✓		
	"Steel skid, no foundations needed"	✓		
Services	12 months factory warranty	✓		
	UltraCare 5 year maintenance program		✓	
Documentation	Performance test certificate	✓		
	Witness test certificate		✓	

## Contact us

**SEDE / HEADQUARTERS**  
Rua Cabral Moncada n° 230  
Bairro Sagrada Família, Luanda

**AREA COMERCIAL / COMMERCIAL AREA**  
Avenida 1° Congresso do MPLA,  
Nr. 9,2°Andar C, Maianga

**ARMAZENS / WAREHOUSES**  
Bairro Capalanca, Viana  
Centro Logistico, Talatona  
Viana Park 6Q5 & 7Q5, Viana

**LOJA / SHOP**  
Rua Rei Katyavala N°107  
Maculusso



[www.facebook.com/grupojosepinto](http://www.facebook.com/grupojosepinto)



[www.twitter.com/grupojosepinto](http://www.twitter.com/grupojosepinto)

**Tel: +244 222 335 512**  
**Tel: +244 222 390 234**  
**Fax: +244 222 371 499**

**TECHNICAL ASSISTANCE:**  
**Tel: +244 222 335 512**

**Email: [comercial@grupojosepinto.org](mailto:comercial@grupojosepinto.org)**  
**NIF: 5403106952**

[www.grupojosepinto.org](http://www.grupojosepinto.org)

Ingersoll Rand Industrial Technologies provides products, services and solutions that enhance our customers' energy efficiency, productivity and operations. Our diverse and innovative products range from complete compressed air systems, tools and pumps to material and fluid handling systems and environmentally friendly microturbines. We also enhance productivity through solutions created by Club Car®, the global leader in golf and utility vehicles for businesses and individuals.



Ingersoll Rand compressors are not designed, intended or approved for breathing air applications. Ingersoll Rand does not approve specialised equipment for breathing air applications and assumes no responsibility or liability for compressors used for breathing air service.

Nothing contained on these pages is intended to extend any warranty or representation, expressed or implied, regarding the product described herein. Any such warranties or other terms and conditions of sale of product shall be in accordance with Ingersoll Rand's standard terms and conditions of sale for such products, which are available upon request.

Product improvement is a continuing goal at Ingersoll Rand. Designs and specifications are subject to change without notice or obligation.